

**NATIONAL BUSINESS AND TECHNICAL EXAMINATIONS BOARD
NATIONAL CERTIFICATE EXAMINATION
GENERAL WOOD WORK
MAY/JUNE 2006**

Section B – Essay – General Wood Work

Attempt FOUR Questions only. All questions carry equal marks

1a. State THREE reasons for staining timber.

Three reasons for staining timber:

- (i) Timber is stained to imitate other timber used for the same project
- (ii) Staining of timber is done to give timber a different colour
- (iii) Staining of timber is done when uniform colour is desired on a job and also to conceal the colour of the timber.

1b. List SIX important points to be kept in mind when using stains.

1b Important points to be kept in mind include:

- (i) Purpose of using the stains
- (ii) Types of stain to be used
- (iii) Colour of the timber to be stained
- (iv) Method of application
- (v) Result expected from staining the wood
- (vi) Appearance of the stained wood.

1c. What are the safety precautions to be observed when using chemical stains

1c. The safety precautions to be observed when using chemical stains are as follows:

- (i) Adherence to manufacturer's instruction
- (ii) Protective hand gloves should be used.
- (iii) Protective air mask should be applied
- (iv) Protective clothing is necessary.

2a. State FIVE conditions that would lead to the breakage of hand saw blade.

2a. The Five conditions that would lead to the breakage of a hand saw are as follows:

- (i) When the tension or the tightness of the blade is too much
- (ii) When the blade is not well jointed by welding
- (iii) When the blade is over used and as a result, it is dull or not sharp
- (iv) When the thickness of the stuff being sawn is too much comparatively to the size of the blade.

- 2b. List FIVE cutting operations which could be carried out on a band saw.
- 2b (i) Curve cutting
(ii) Concave cutting
(iii) Straight cutting
(iv) Template cutting
(v) For conversion of timber.
- 3a What is adhesive?
- 3a. Adhesive is a substance available in powder or liquid form used for bonding two surfaces together. It could be wood to wood, iron to wood, leather to wood etc.
- 3b. Differentiate between the following principles of glue;
- (i) Cohesion
(ii) Adhesion
- (i) Cohesion refers to the entity or whole chemical of the glue to cure why:
(ii) Adhesion is the ability of the specific glue to cure. These two terms are relative.
- 3c. State FIVE properties required in a wood glue.
- 3c. Five properties required in a wood glue:
- (i) water resistance
(ii) resistance to bacteria
(iii) stain free
(iv) easy appreciability
(v) Ability to withstand degree of heat.
- 4a. Name THREE types of screws used in the wood workshop
- 4a (i) Countersunk screw
(ii) Round head screw
(iii) raised head screw
- 4b. Sketch ONE of the screws in a above and label its parts.

4b. Countersunk Screw (labeled sketch)

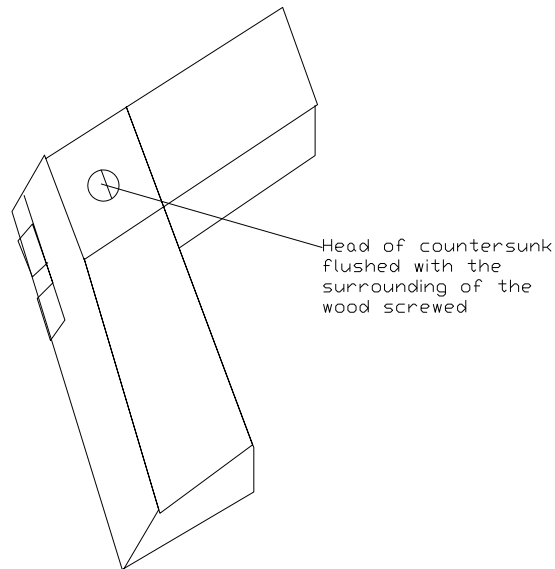
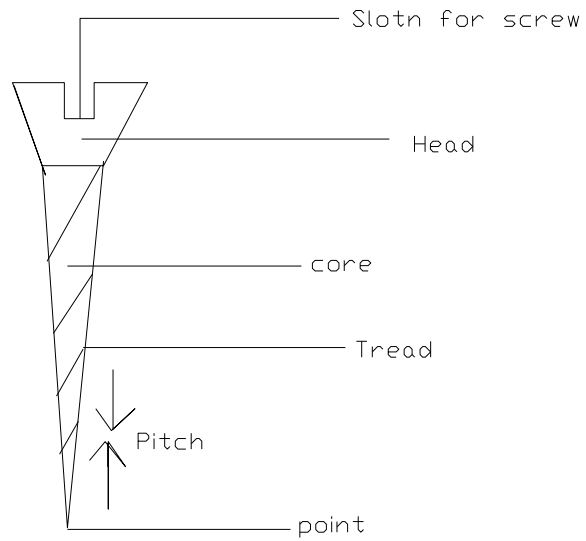

5a. Sketch neatly the following woodwork joints:

- (i) bare faced mortise and tenon joint.
- (ii) Stub mortise and tenon joint
- (iii) Mitre mortise and tenon joint.

5(a)i. Bare faced mortise and tenon joint.

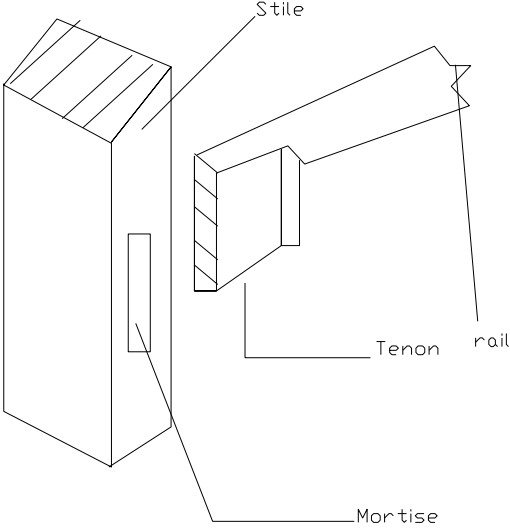

ii. Stub mortise and tenon.

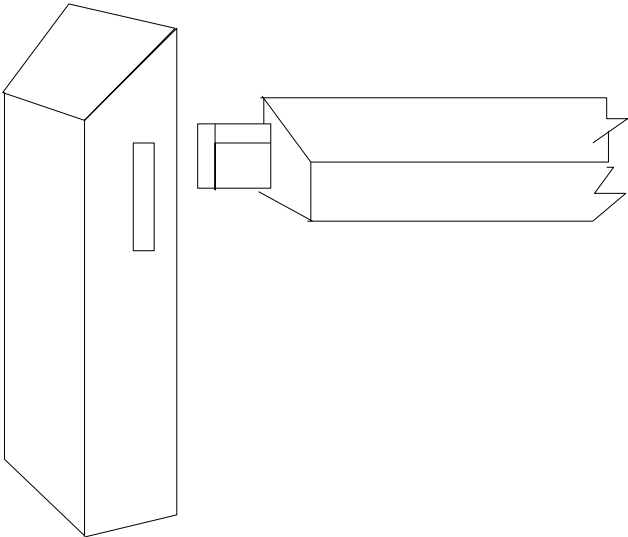

iii. Mitred mortise and tenon.

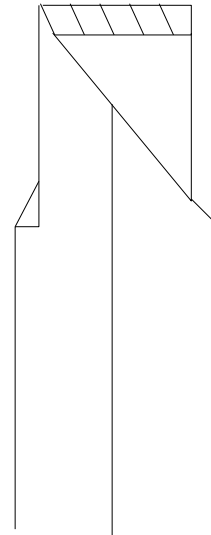
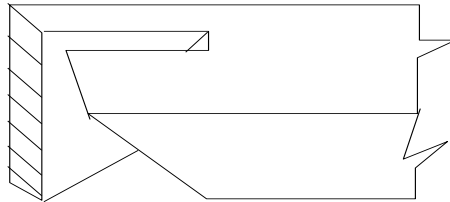

- 5b. State where each of the joints sketched in 5(a) above is used in the construction of framework.
- 5b (i) Bare faced mortise and tenon joint is used in stool and cupboard construction.
- (ii) Stub mortise and tenon joint is used in the construction of door frames i.e. flush door.
- (iii) Mitre mortise and tenon joint is employed in solid or strong frame construction.